

F-Type Spring Nut

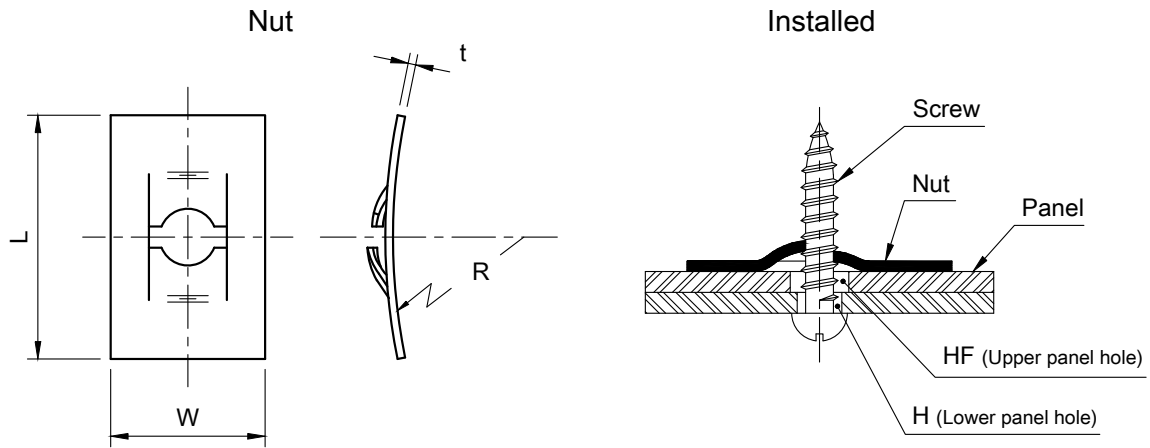

Unit : mm

Size-No.	Applicable screw	Nut				Panel		
		W	L	R	t	H	HF	
FSN-	3001	M3 x 0.5	10	16	40	0.3	3.2	4
	4001	M4 x 0.7	13	20	50	0.4	4.3	5
	5001	M5 x 0.8	13	20	50	0.15	5.3	6
	6001	M6 x 1.0	13	20	50	0.5	6.4	7

• Material = carbon steel Hardness = HRC40~50 Finish = black oxide

Adjustable Lock Nut

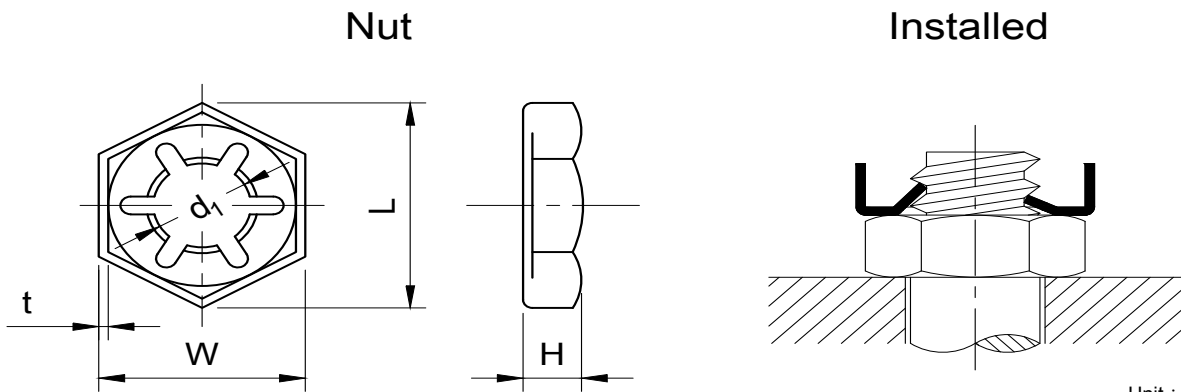

Unit : mm

Size-No.	Applicable screw	Nut					
		d ₁	L	W	H	t	
ALN-	4	M4	3.5	8.1	7	2.5	0.3
	5	M5	4.5	9.2	8	2.5	0.4
	6	M6	5.3	11.5	10	3	0.4
	8	M8	6.9	15.0	13	3.5	0.5
	10	M10	8.6	19.6	17	4	0.5
	12	M12	10.4	21.9	19	4.5	0.6
	14	M14	12.0	25.4	22	5	0.6
	16	M16	14.1	27.7	24	5	0.7
	18	M18	15.5	31.2	27	5.5	0.7
	20	M20	17.6	34.6	30	6	0.8
	22	M22	19.6	36.9	32	6	0.8
	24	M24	21.0	41.6	36	7	0.9
	27	M27	24.2	47.3	41	7	1.0
	30	M30	26.6	53.1	46	8	※1.0
	33	M33	29.8	57.7	50	8	1.2
	36	M36	32.2	63.5	55	9	※1.2
39	M39	35.2	69.3	60	9	※1.2	
42	M42	37.6	75.0	65	11	※1.5	
45	M45	40.9	80.8	70	12	1.5	
48	M48	43.9	86.5	75	14	1.6	
52	M52	48.2	92.4	80	16	※1.6	

• Material = carbon steel Hardness = HRC38~46 Finish = black oxide

Note : ※ mark are according to our company's specification.