

## Grip type Retaining Ring

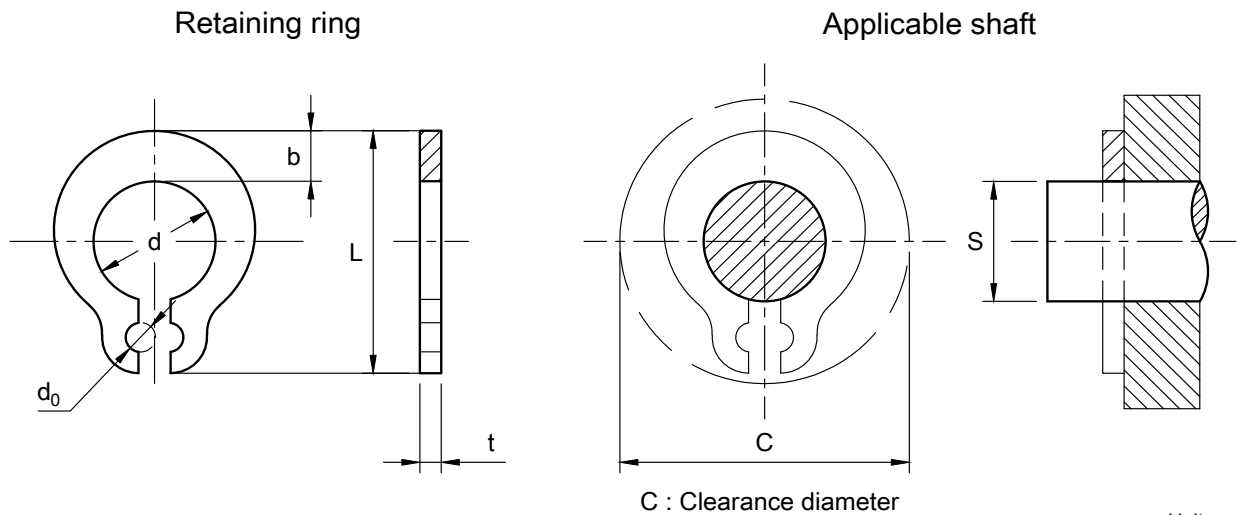

Unit : mm

Size-No.	Retaining ring							Applicable shaft			
	d		b	L	d <sub>0</sub>	t		C	S		
	Basic	Tol.				Basic	Tol.		Max.	Basic	Tol.
GTW-	1.5	1.4	+0.05 -0.08	0.75	3.8	0.9	0.4	±0.03	5.3	1.5	±0.02
	2	1.9	+0.03 -0.1	1	4.8	0.9	0.6	±0.04	6.4	2	
	2.5	2.35	+0.05 -0.08	1.2	5.4	0.9	0.6		7.7	2.5	
	3	2.85	+0.05 -0.1	1.4	6.3	0.9	0.6	±0.05	10.3	4	±0.03
	4	3.8	+0.05 -0.1	1.8	8.4	1.2	0.8		11.4	5	
	5	4.75	±0.08	2.2	9.8	1.2	0.8	±0.06	13.5	6	±0.05
	6	5.7	±0.08	2.4	11.5	1.4	1		14.8	7	
	7	6.7	±0.1	2.7	12.8	1.4	1	15.8	8		
	8	7.7		3	14.1	1.4	1	19.8	9		
	9	8.65		3.3	16.6	2	1.2	20.8	10		
10	9.65		3.5	17.8	2	1.2					

- Material = carbon steel
- Hardness = HRC44~52
- Finish = black oxide or phosphate coating (ACP)