

Spring Pin (For light duty)

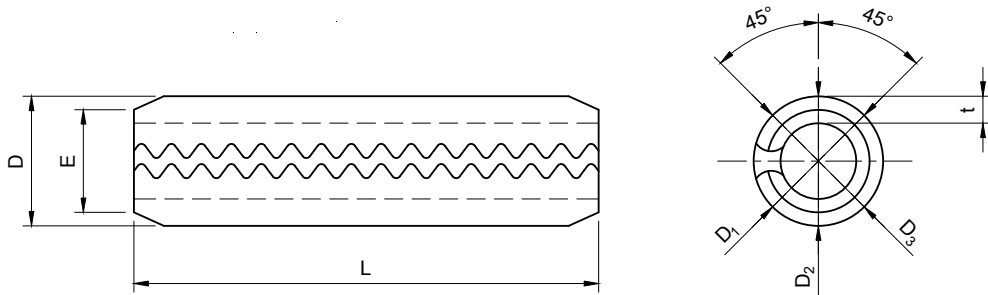

Unit : mm

Norminal diameter		1.6	2	2.5	3	4	
Dimension	D	Max.	1.8	2.25	2.75	3.25	4.4
		Min.	1.7	2.15	2.65	3.15	4.2
	t	Basic	0.15	0.2	0.25	0.3	0.4
Shear strength	Min.	Max.	1.5	1.9	2.4	2.9	3.9
		kgf	95	158	247	356	629
Applicable Hole	Tol.	Basic	1.6	2	2.5	3	4
			+0.08 0		+0.09 0		+0.12 0

Length L		Nominal diameter D				
Basic	Tol.	1.6	2	2.5	3	4
4	+0.5 0	•				
5		•				
6		•				
8	+1 0	•				
10		•				
12		•				
14		•				
16		•				
18		•				
20		•				
22		•				
25		•				
28		•				
32						
36						
40						

- Material = carbon steel Hardness = HRC45~50 Finish = black oxide
 - Material = stainless steel
- Note : D shall be the average of the D₁, D₂, and D₃ diameter.

Snap Pin (R-Pin)

Snap pin

Applicable shaft

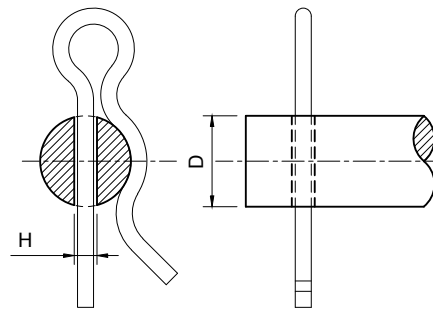
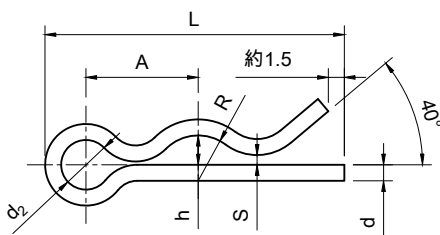

Unit : mm

Size-No.	Snap pin								Applicable shaft		
	d		d ₂	A	R	h	S	L	D	H	
	Basic	Tol.	Approx.	Approx.	Approx.	Approx.	Max.	Approx.	Ref.	Ref.	
SSP-	4	1	±0.02	3	6	2	1	0.5	16.3	4	1.2
	5	1		3	6.5	2.5	1.5	0.5	17.9	5	1.2
	6	1.2	±0.03	3.6	7.8	3	1.8	0.6	21.2	6	1.5
	8	1.6		4.8	10.4	4	2.4	0.8	27.7	8	1.9
	10	1.8		5.4	12.2	5	3.2	0.9	32.6	10	2.2
	12	1.8		5.4	13.2	6	4.2	0.9	35.8	12	2.2
	14	2		6	15	7	5	1	40.6	14	2.4
	16	2		6	16	8	6	1	43.8	16	2.4

- Material = SWB or SWRH 57-82 gradient Hardness = HRC40~50 Finish = Zinc plating
- Note : "d" stands for the diameter of the material.